

## Characteristics

- Nominal pressure PN 25
- Regulating capability  $\frac{k_{vs}}{k_{vr}} > 25$
- Double seated
- Characteristic - almost linear

## Applications

Control valves type H2F are designed for use in regulating high pressure hot water, steam and heat transfer oil, ammonia, freon, etc.

The double-seated valves are used in installations where the system pressure necessitates a closing force greater than available in the actuator programme for a single-seated valve.

The valves are used in conjunction with temperature or pressure differential regulators for controlling district or central heating plants, industrial processes or marine installations.

## Dimensioning

For sizing of control valves and selection of actuators please see "Quick Choice" datasheet no. 9.0.00.

## Design

The valve components – spindle, seats and cone – are made of stainless steel. The valve body is made of cast steel GP240GH (GS-C25) with flanges drilled according to EN 1092-1. The connection thread for the actuator is G1B ISO 228. The valves are double-seated and designed for tight closure. The leakage rate is less than 0.5% of the full flow (according to VDI/VDE 2174).

## Quality assurance

All valves are manufactured under an ISO 9001 certification, and are pressure and leakage tested before shipment.

For marine applications the valves can be supplied with relevant test certificates from recognized classification societies.

## Function

Without the actuator being connected, the valve is held in open position by means of a spring. With pressure on the spindle the valve will close.

In connection with our thermostats or electronic actuators, the valves will close at rising temperatures. For cooling circuits a reverse acting valve can be used.

The linear characteristic will not cease, until the flow has dropped below 4% of the full flow.



## Technical Data

<b>Materials</b>	
- Valve body	Cast steel GP240GH (GS-C25)
- Components	Stainless steel
-Bolts, nuts	24 CrMo 4/A4
Nominal pressure	PN 25
Seating	Double seated
Valve characteristic	Almost quadratic
Regulating capability	$\frac{k_{vs}}{k_{vr}} > 25$
Function	Closing with pressure on spindle
Leakage rate	$\leq 0.5\%$ of $k_{vs}$
Temperature range	See pressure/ temperature diagram
Mounting	See page 2
Flanges drilled according to	EN 1092-1 PN 25
Counter flanges	DIN 2635
Colour	Green

**Note:** All Clorius valves are approved in accordance to the Pressure Equipment Directive (PED). Valve type 150 H2F in only approved for nominal pressure PN 16, but for applications not effected by the PED, valve type 150 H2F can be delivered for nominal pressure PN 25.

Subject to change without notice.

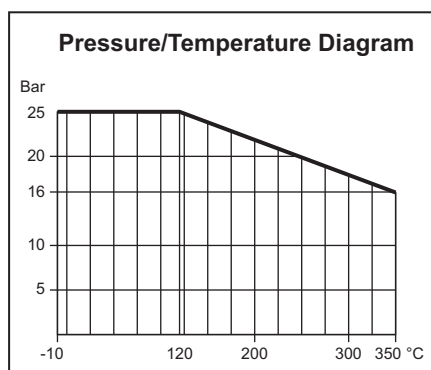

Specification					
Type	Flange connection DN in mm	Opening mm	$k_{vs}$ -value m <sup>3</sup> /h	Lifting height mm	Weight kg
100 H2F	100	100	125	20	38
125 H2F	125	125	215	20	73
150 H2F	150	150	310	20	76

### Definition of $k_{VS}$ -value

The  $k_{VS}$ -value is identical to the IEC flow coefficient  $k_V$  and defined as the water flow rate in m<sup>3</sup>/h through the fully open valve by a constant differential pressure,  $\Delta p_V$ , of 1 bar.

### Mounting

Up to 170°C the valve can be installed vertically as well as horizontally. For media temperature above 170°C, a cooling unit of type KS has to be applied. It must then be installed with electric actuator/ thermostat downwards, and according to the following instructions:

Valve Temperature	Cooling Unit	Suitable for
170°C - 250°C	KS-4	All actuators
250°C - 350°C	KS-5	Thermostats
250°C - 350°C	KS-6	El. actuators

### Strainer

It is recommended to use a strainer in front of the control valve if the liquid contains suspended particles.

### Accessories

#### Manual Adjusting Device

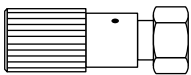

The device has a built-in stuffing box. For sealing and manual operation of valves when an actuator has not been fitted, e.g. during periods of construction.

#### Cooling Unit KS-4

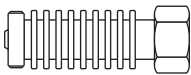

Cooling unit protecting the stuffing box of the electric actuator / thermostat. To be applied at valve temperatures between 170°C and 250°C.

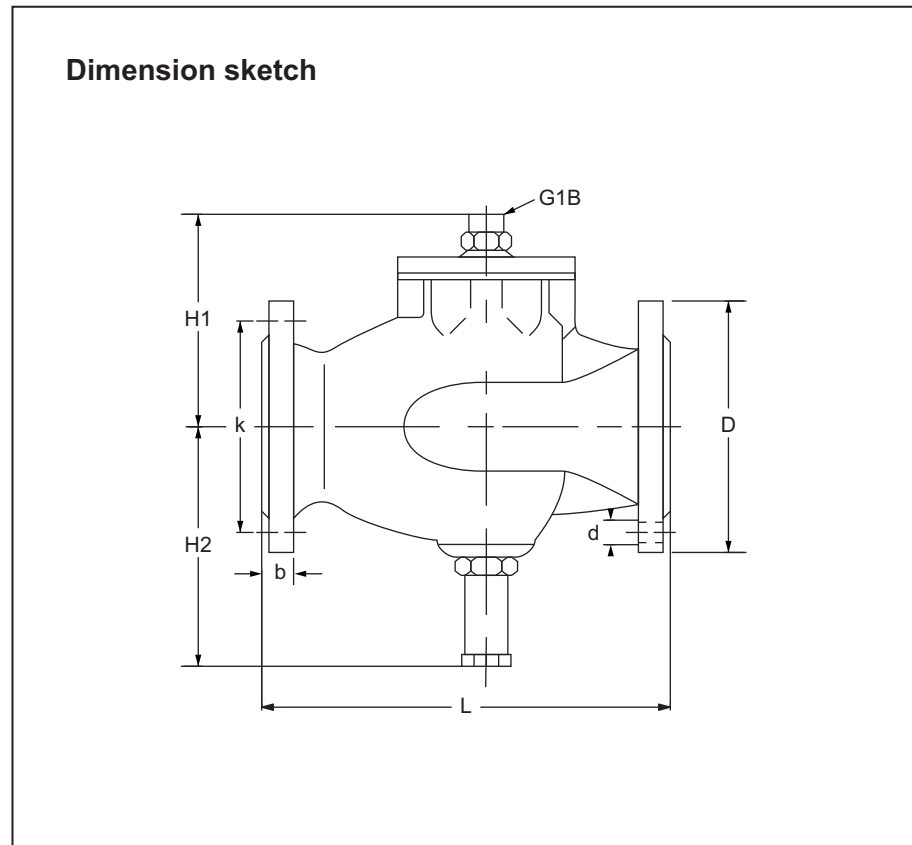

#### Dimensions

Type	L mm	H1 mm	H2 mm	D (dia.) mm	b mm	k (dia.) mm	d mm dia. (number)
100 H2F	350	185	209	235	24	190	23x(8)
125 H2F	400	240	230	270	26	220	27x(8)
150 H2F	400	240	230	300	28	250	27x(8)

#### Cooling Unit KS-5

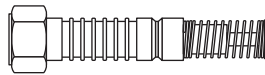

Cooling units with built-in bellow glands, replacing stuffing box of thermostat (KS-5) or electric valve actuator (KS-6). Must be applied at valve temperatures above 250°C.

#### Cooling Unit KS-6

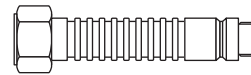

Subject to changes without notice.